

## Portable concrete pumps PC 506

### Description

A complete range, whether on small job sites, shotcrete pumping or big civil works. In every situation, these pumps all have the basic characteristics of stability, low running costs and pumping consistency. Available in diesel or electric version, noiseless or flameproof. All pumps are provided with excellent standard supply, complete with a wide choice of accessories which determine their versatility, making them ideal for work on big job-sites outside town and in town centres.



### Dimensions and performance diagrams

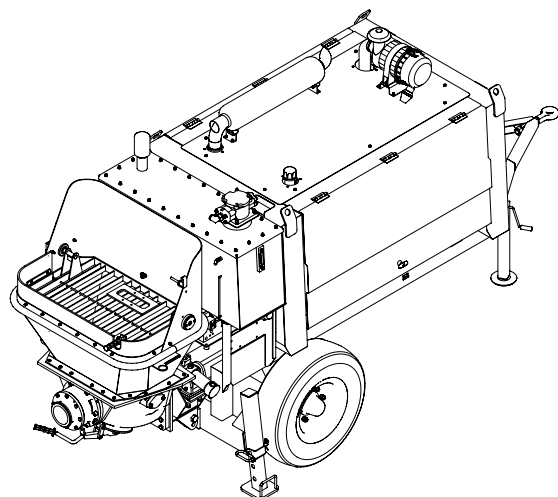
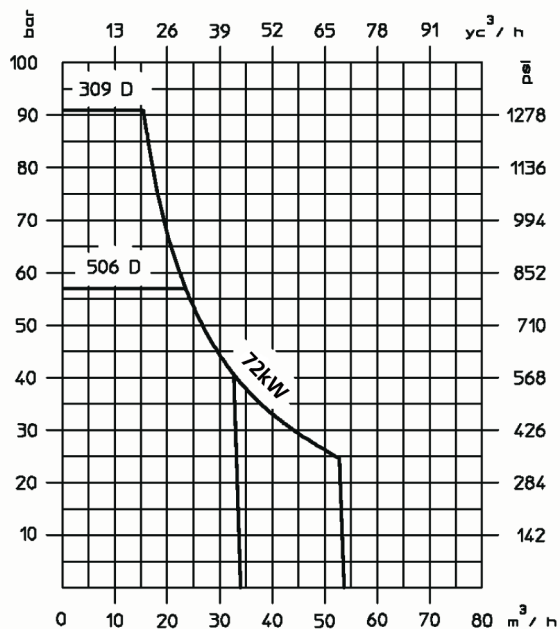
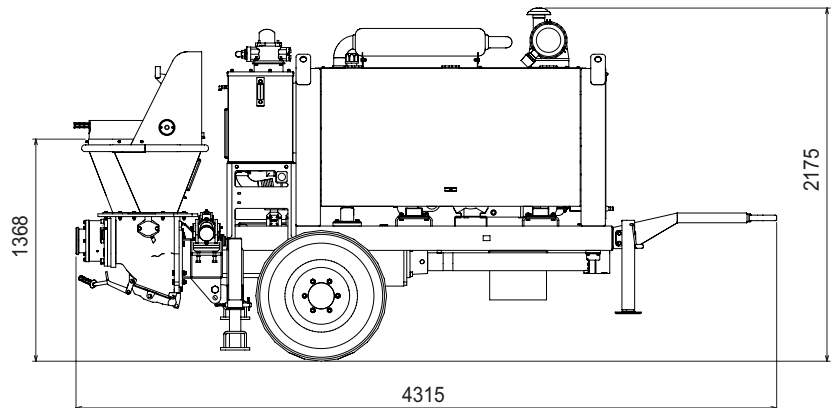
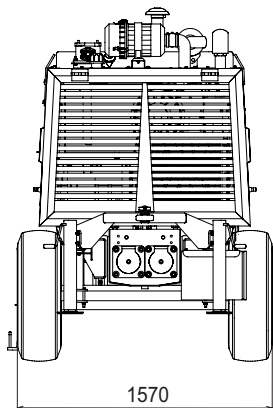

# Portable concrete pumps PC 506

## Main features

The Cifa portable concrete pump series offers a wide range of models which satisfy the various needs of concrete pumping and handling both in tunnels and above ground, over long distances and at considerable heights.

The Cifa original pumping unit presents characteristics of resistance, long life and exceptional performances with any type of concrete.

All models have a rigid monoaxle trailer complete with drawbar, four manual adjustable outriggers and two rubber wheels.

The power source is provided by separate engine (Diesel or Electric).

The main pump is an axial piston type with variable flow and constant power; gear pump is used for auxiliary services.

- 'S' shaped valve for any type of concrete, made of special steel
- Rapid valve exchange
- Ideal operation even at high pressures with continuous and smooth pumping flow
- Automatic wear compensation
- Hydraulic system in open circuit
- Transformation of the pumping units from high to low pressure or viceversa
- Low noise
- Low running costs
- Easy maintenance and quick cleaning operations
- Machines can work up to -25°

## Standard equipment

- Electric vibrator on the hopper grid
- Rigid monoaxle trailer
- Drawbar
- N° 4 manual outriggers
- Concrete outlet piping with bend and counterbend reduction device up to 5"
- Hydraulically driven water pump 70 l/min - 20 bar
- Concrete flow rate regulator on board
- Washing pipe complete with nozzle
- Connection flange for washing
- N° 2 sponge rubber balls
- Remote control with 20m cable
- Acoustic signal for diesel engine breakdown
- One colour painting

## Optionals

- Multistage centrifugal water pump (300 l/min - 20 bar)
- Hydraulically controlled air compressor, bicilindrical, two-stage capacity 700 l/min intaken, max. pressure 10/12 bar, complete with accessories, stopballs cage and stub pipe
- Stopballs cage and stub pipe diam. 5.5" with joint
- Catalytic silencer for Deutz engines
- Water silencer for Deutz engines

## Technical data

Model		PC 506	PC 309
Drive power D/E	kW	72/55	72/55
Max. theoretical output	m <sup>3</sup> /h	52	34
Max. pressure on concrete	bar	57	91
Max. number of cycles per minute		36	24
Concrete cylinders (diam. x stroke)	mm	176x1000	176x1000
Concrete hopper capacity	/	350	350
Rod side drive □ / Piston side drive ◆		□	◆

Technical data and characteristics subject to modifications without notice